

SHOWER TRAY SPECIFICATION GUIDE - STEP-IN

See page 90 for details of How to order

FERNDALE MODEL

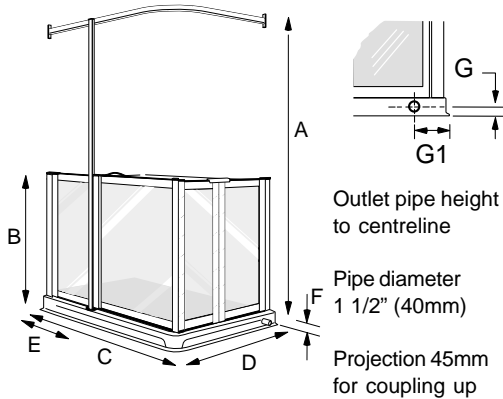

Right hand shower tray Illustrated with trifold door option

SHOWER CHAIR COMPATIBILITY (ALL MODELS)



Self propelled models



Attendant propelled models

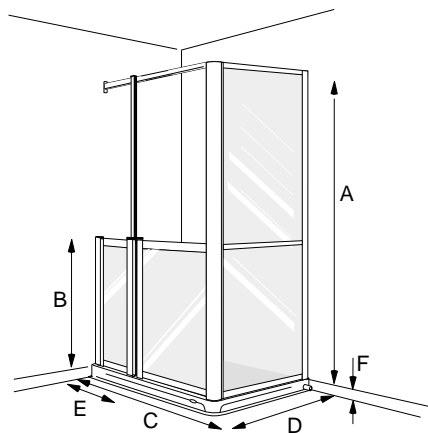

Right hand shower tray Illustrated with Single door option

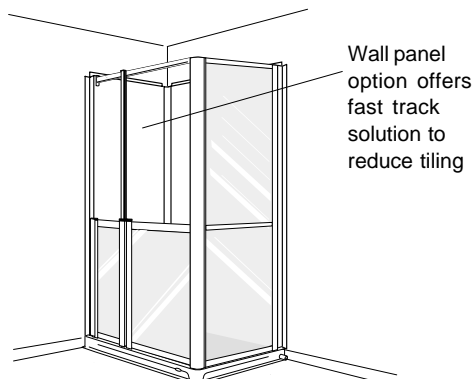

Right hand shower tray Illustrated with Single door option and wall panel option.

Wall panel option also available for trifold version.

REF	DIMENSIONS	FERNDALE LEFT HAND TRAY	JAMB DETAIL
A	1950		Plan view
B	820		
C	925		
D	710		
E	176		
F	120		
G	37		
G1	100		
REF	DIMENSIONS	FERNDALE RIGHT HAND TRAY	JAMB DETAIL
A	1950		Plan view
B	820		
C	925		
D	710		
E	176		
F	120		
G	37		
G1	100		

Thick black line denotes wall position

Notes

Door size 877mm x 655mm (including jamb). Front jamb size is 176mm.
Internal showering area: L= 857mm x W=635mm

1. Dimension A is to the top of the assistance pole (from the shower tray)
2. Dimensions C&D are measured from the face of the tiling lip

REF	DIMENSIONS	FERNDALE LEFT HAND TRAY	JAMB DETAIL
A	1950		Plan view
B	820		
C	925		
D	710		
E	176		
F	120		
G	37		
G1	100		
REF	DIMENSIONS	FERNDALE RIGHT HAND TRAY	JAMB DETAIL
A	1950		Plan view
B	820		
C	925		
D	710		
E	176		
F	120		
G	37		
G1	100		

Thick black line denotes wall position

Notes

Door size 877mm x 655mm (including jamb). Front jamb size is 176mm.
Internal showering area: L= 857mm x W=635mm

1. Dimension A is to the top of the assistance pole (from the shower tray)
2. Dimensions C&D are measured from the face of the tiling lip

SYMBOLS:

Bulk/oversized item



Made to order (see P200)



Tel: 0800 917 0399

www.chilterninvadex.co.uk

Fax: +44 (0) 1869 365588

sales@chilterninvadex.co.uk