

# Showering and Bathing Technical Specification

## Wet floor kit

The Chiltern Invadex Wet Floor Kit features a unique easily installed and filterless 12 volt pump, which quietly pumps the waste water away in a wet floor installation.

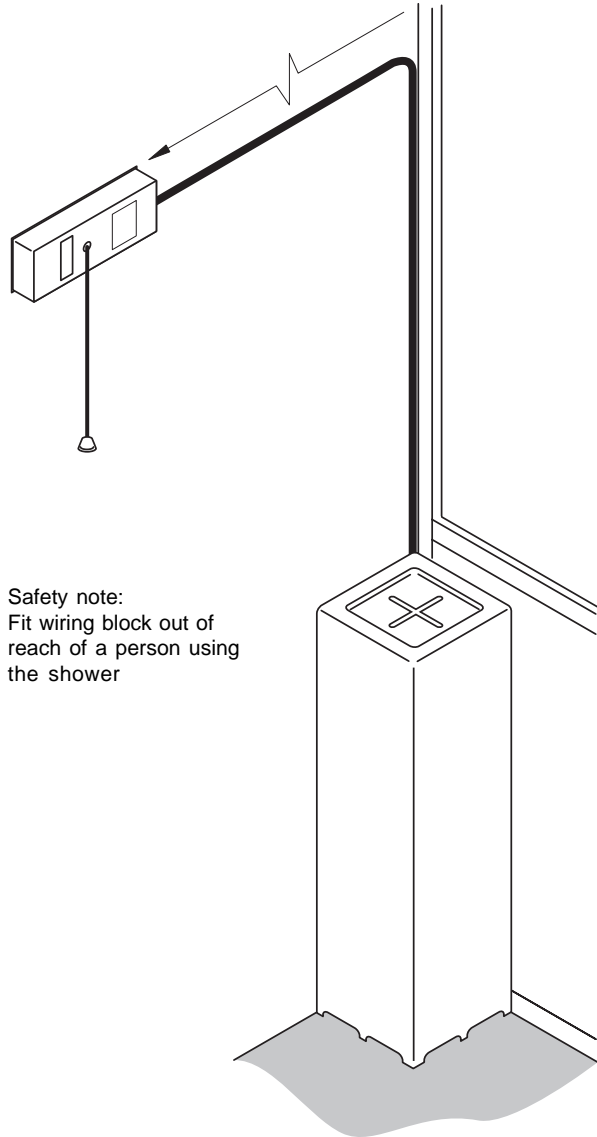

SIDE ELEVATION

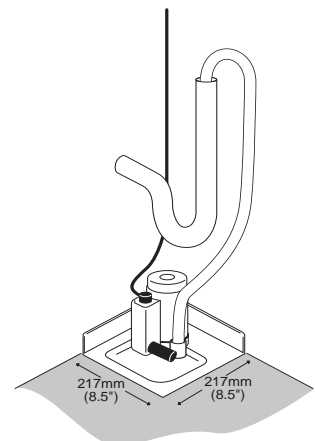
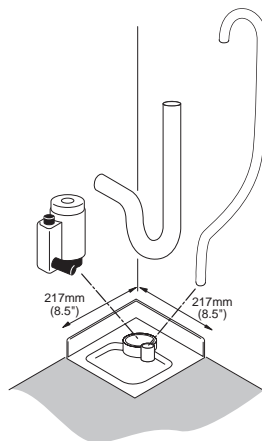
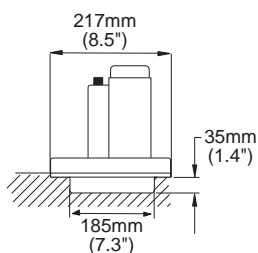

Chiltern Invadex Ltd  
Chiltern House  
6 Wedgwood Road Bicester  
Oxon OX26 4UL  
Tel: 01869 246470  
Fax: 01869 247214

Overseas enquiries  
Tel: +44 (0)1869 365545  
Fax: +44 (0)1869 365567

Chiltern Invadex Ltd  
66-68 Manchester Road  
Chapel-en-le-Frith High Peak  
SK23 9TP  
Tel: 01298 816366  
Fax: 01298 816106

Chiltern Invadex (NI) Ltd  
5 Balloo Way  
Balloo Industrial Estate Bangor  
County Down BT19 7QZ  
Tel: 028 9145 0497  
Fax: 028 9127 0046

Chiltern Invadex  
St. Kierans Enterprise Centre  
Furze Road Sandyford Industrial Estate  
Foxrock Dublin 18  
Tel: 01 286 2726  
Mob: 086 829 7541



FM 40009  
FM 21085



Bicester, Chapel-en-le-Frith and Dukinfield are  
BS EN ISO 9001 approved (FM 40009) .

Bangor Northern Ireland is  
BS EN ISO 9002 approved (FM 21085).

Brochure Hotline

**FREEPHONE 0800 917 0399**

To request brochures on other  
products in our range

- Allows water to be pumped away on a wet floor installation where conventional drainage is difficult.
- Quiet and safe 12 volt pump quickly and efficiently pumps waste water away to bath or sink waste height.
- Kit contains:
  - flexible drain hose
  - wiring block
  - 12 volt pump
  - pump lead
  - corner cover with built-in soap dish
  - non-slip mat
- Easy to install with the minimum of structural disruption within most screed levels.
- Tough durable material for long lasting appearance.
- Wiring block that controls pump, shower and extractor fan from one electrical source.
- For an unobstrusive addition to wet floor areas the standpipe and box can be cut to any height (just above pump height).

**Note:**

All electrical installations must comply with I.E.E. regulations and must be carried out by a qualified electrician.

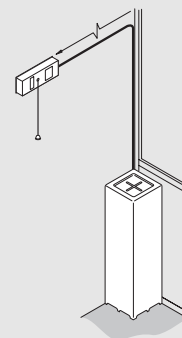

Dimensions are for guidance only

web: [www.chilterninvadex.co.uk](http://www.chilterninvadex.co.uk)