

# Ceiling Track Hoist

## Wispa 100 Series Hoist Range



Moving and Handling Solutions

## Wispa Hoist Range

### Moving and handling solutions for home, leisure and caring environments

Healthcare providers have been working towards safer patient handling policies since the inception of the Manual Handling Operations Regulations. The Health and Safety Executive has stated that handling heavy or awkward loads, poor work postures, or repetitive movements can result in musculoskeletal disorders, including back injuries, pain and muscle strain. The risk of sustaining injury can be greatly reduced by selecting appropriate moving and handling equipment and by using it effectively.

There are a number of factors which should be considered when choosing suitable hoisting equipment, such as the environment, type of disability, size and required level of independence of the person to be hoisted, carer physical strength and size are also important factors which should influence selection. This assessment of circumstance combined with the vast array of equipment available can make hoist selection a daunting prospect. Chiltern Invadex have a team of experienced Surveyors who are available to conduct free of charge site visits to provide advice on the most suitable piece of equipment to meet user needs and property constraints.

#### Hoist Range

Wispa Mobile Hoist



WispaLite Portable Hoist



Wispa 100+



Wispa 300



## Safety

The Chiltern Invadex range of moving and handling equipment has been carefully designed and tested to meet the requirements of BS EN ISO 10535 and carries the **CE** mark in accordance with the Medical Devices Directive. Hoist performance is continually monitored through extensive on-going field trials and trend analysis.

Every hoist is subject to rigorous testing prior to leaving our Oxfordshire manufacturing base.

## Versatility

Flexible design means that the Wispa range of track hoists can be ceiling, wall or gantry mounted.

A range of track accessories including bends, turntables, through door and X-Y systems provide the versatility to suit almost any situation.

X-Y systems offer complete room coverage and have the option for powered or manual traverse.

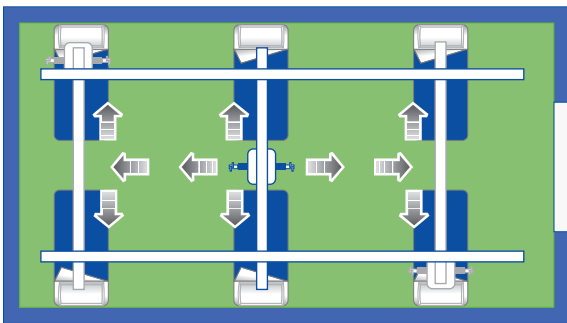

Combinations of equipment allow hoist installations to be designed to suit various property layouts including allowing access to the most confined areas such as en-suites, where limited space may hinder the use of a mobile hoist.

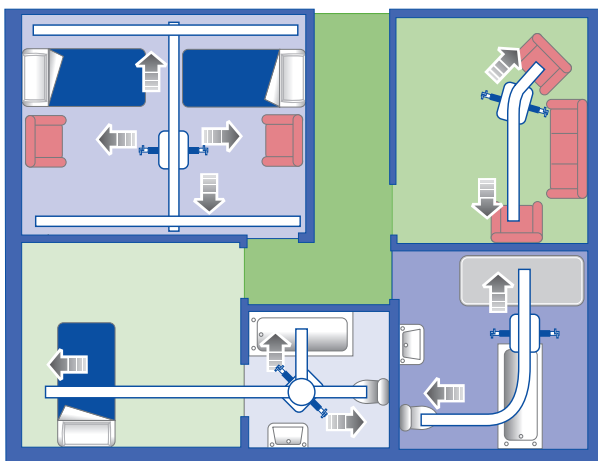

## Survey and Architect Guidance

Chiltern Invadex employ a nationwide team of experienced technical surveyors who are able to conduct site visits to assist with the specification of equipment and advise on structural requirements. A scale plan of the proposed layout can be provided along with CAD drawings for incorporation within Architects drawings and 3D representations.

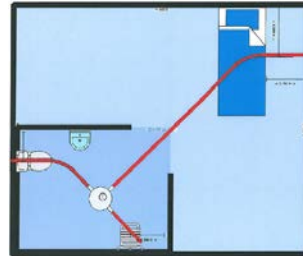

A detailed specifiers guide is available to assist architects and scheme designers. To obtain a copy please email [technical@chilterninvadex.co.uk](mailto:technical@chilterninvadex.co.uk).

## Installation

Our engineers are experienced in the safe and efficient installation of lifting equipment in a variety of environments including;

- Occupied domestic properties
- Hospital wards and nursing homes
- Schools, colleges and universities
- Sports facilities and hydrotherapy pools
- Offices and public buildings
- Changing Places developments
- Construction and refurbishment sites (1st and 2nd fix works can be arranged)
- Mobile homes, stables and boats

The company is CHAS, Constructionline and NICEIC accredited.



# Wispa 100+ Range

The Wispa 100+ range of ceiling mounted hoists provides safe and comfortable lifting combined with simplicity of use.

## Models and Lifting Capacity

Wispa 100+ 20 stone (130kg) (286lb)

Wispa 100+ Turbo 31 stone (200kg) (440lb)

Each provides safe and controlled transfer from the bed, chair, floor, toilet or bath at the touch of a button.



The hand control features light touch pneumatic buttons creating a safe operating system, ideal for bathing, and incorporates colour coded buttons which correspond to coloured arrows on the hoist to give clear indication of the direction of travel.



## Power options to suit

Mains powered transformer models (W, WL) have no battery to recharge and are ideal for tracks up to 3 metres.

Battery models (WB, WLB) offer increased options for track length and layout with their own independent power supply on board.

## Economical and simple to recharge

Always ready to go, Wispa is easy to charge. Simply return the hoist to the track end to start the charging process.



## Safe, controlled handling

**Limiting device** - to stop the maximum load being exceeded.

If the operator is distracted a limit switch prevents the patient being raised too high or lowered too far.

**Emergency stop with reset facility** - should an emergency arise, this simple feature provides reassurance for both user and carer.

**Emergency lowering** - in case of battery failure a lowering device is fitted.

**Lift motor has a self lock facility** - to prevent the user being lowered unintentionally.

# Wispa 100+

## Hoist Features

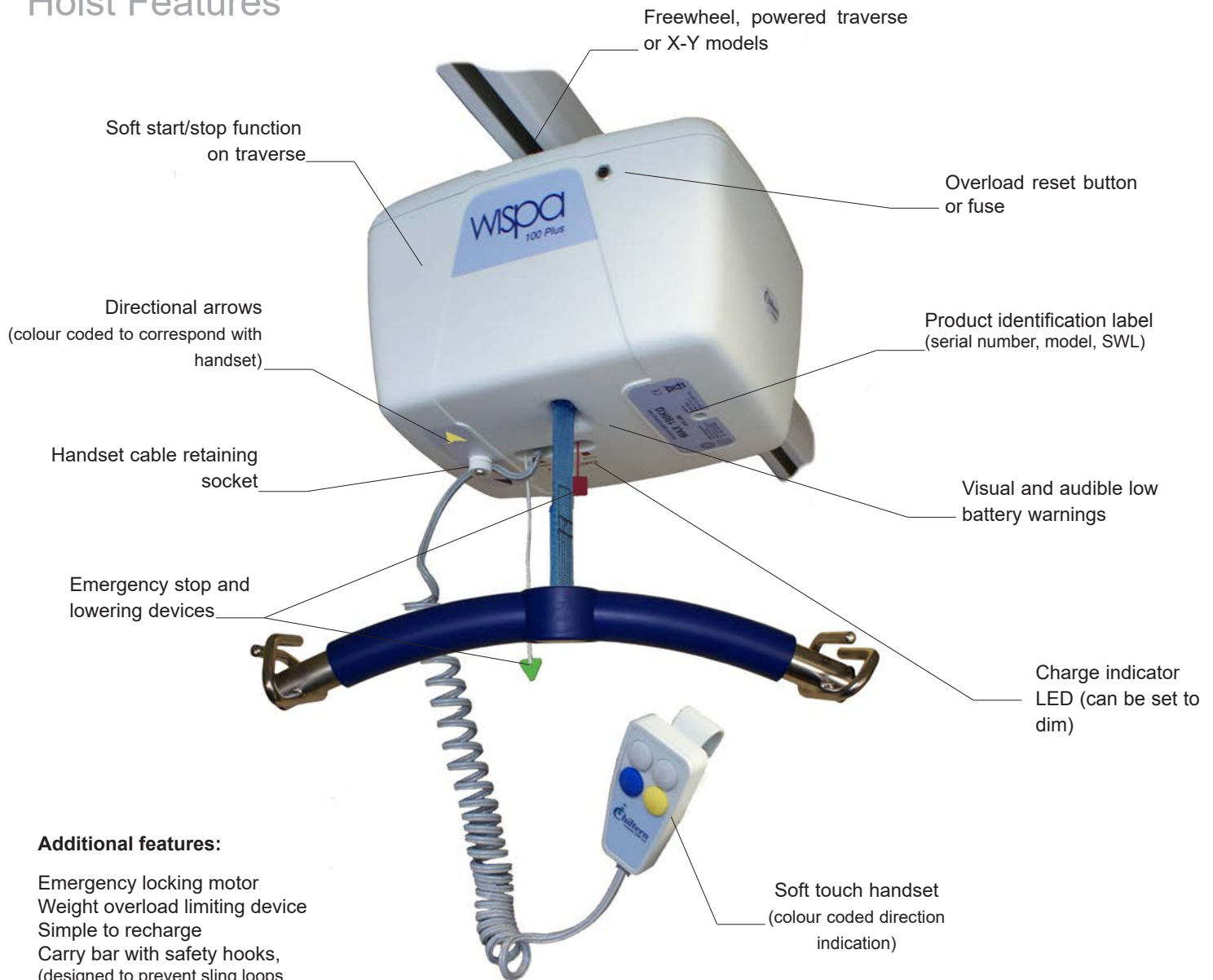

### Additional features:

- Emergency locking motor
- Weight overload limiting device
- Simple to recharge
- Carry bar with safety hooks, (designed to prevent sling loops detaching)
- Available in both, 130kg (20st) and 200kg (31st) safe working load versions
- Hoist idle alarm

### Technical Information

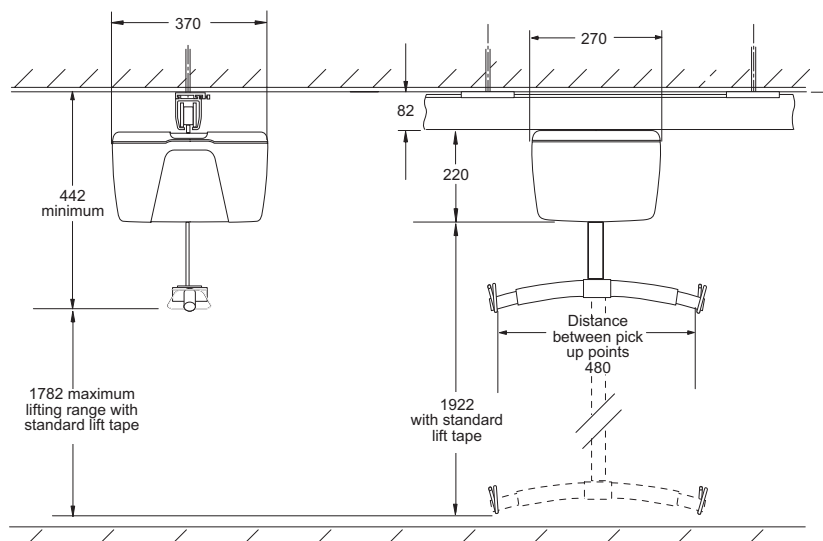

**Chiltern Invadex (UK) Ltd**  
Unit 6C Thorpe Drive  
Banbury  
Oxfordshire  
OX16 4UZ  
Tel: 01869 365500

E-mail: [sales@chilterninvadex.co.uk](mailto:sales@chilterninvadex.co.uk)  
Web: [www.chilterninvadex.co.uk](http://www.chilterninvadex.co.uk)

**Overseas enquiries**  
Tel: 0044 1869 365500  
Fax: 0044 1869 365588

## Other Product Ranges from Chiltern Invadex

### Shower Commode Chairs



TransAqua



AquaMaster A06



AquaMaster Closomat  
Range

### Tilt in Space Bathing Range



Aquamaster Tilt in Space Chair



Washington Tilting Shower Cradle

### Shower Trolleys, Cradles and Stretchers



T1 shower trolley, now available  
in 20 colour options



Washington Cradle



T12 fold up stretcher



T3 Paediatric trolley - now  
available in 20 colour options

### Shower Enclosures, Wet Floors and Cubicles - full installation service available



Shower WC cubicle

EasiDec wet floor

Sandwell level access tray



FM 553189